

UNITHERM 3 ALL-IN-ONE R32

SERIES

INVERTER

R32















+10°C ... +48°C



-25°C ... +35°C



- 
 -25°C... +48°C
- 
 Max. water temperature
- 
 Energy Efficiency
- 
 Self-diagnostics
- 
 Auto-protection
- 
 Anti-corrosive Coating
- 
 2-Stage Compressor
- 
 Timer
- 
 Wired Controller
- 
 BMS Control Systems
- 
 Intelligent Defrosting
- 
 Intelligent Control
- 
 Wi-Fi

INDOOR UNIT

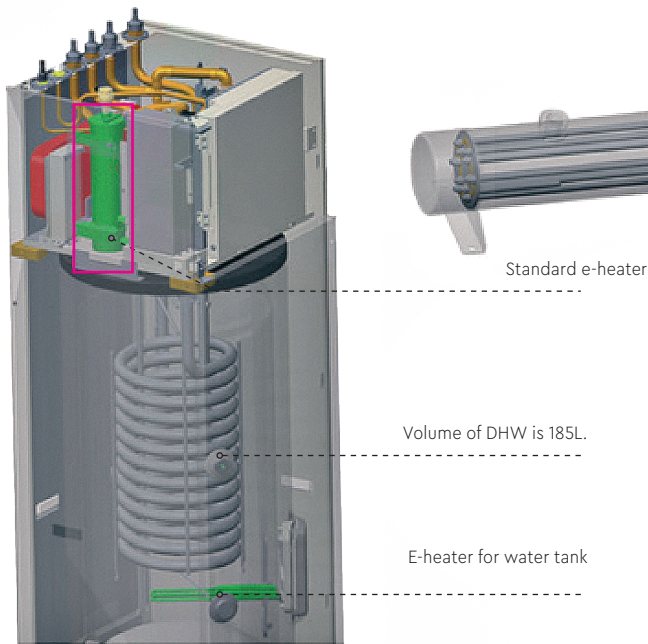
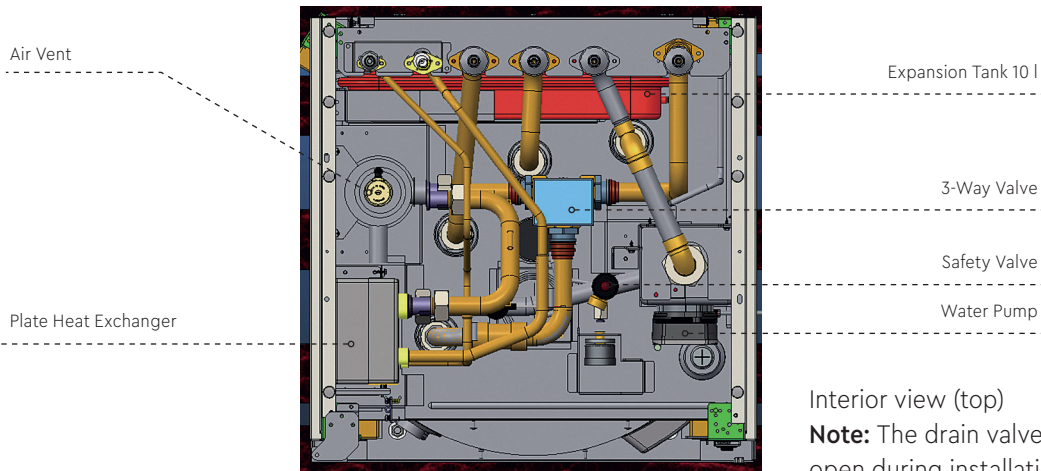

See the table below regarding the configuration of the electric heater for heating and domestic hot water.

| | E-heater for heating | E-heater for DHW |
|--------------------|----------------------|------------------|
| CH-HP6.0WTSIRK3(I) | 1.5 + 1.5 kW | 3 kW |
| CH-HP8.0WTSIRK3(I) | 3 + 3 kW | 3 kW |
| CH-HP10WTSIRK3(I) | | |
| CH-HP12WTSIRK3(I) | 3 + 3 kW | 3 kW |
| CH-HP14WTSIRK3(I) | | |
| CH-HP16WTSIRK3(I) | | |

OUTDOOR UNIT IS UNIVERSAL FOR SPLIT AND ALL-IN-ONE SERIES

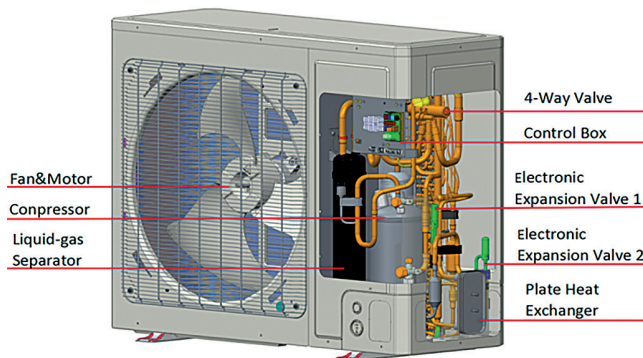

Two-Stage technology enables efficient heating of water at extremely low temperatures without additional losses of electricity

ALL-IN-ONE SERIES WITH BUILT-IN DHW WATER TANK

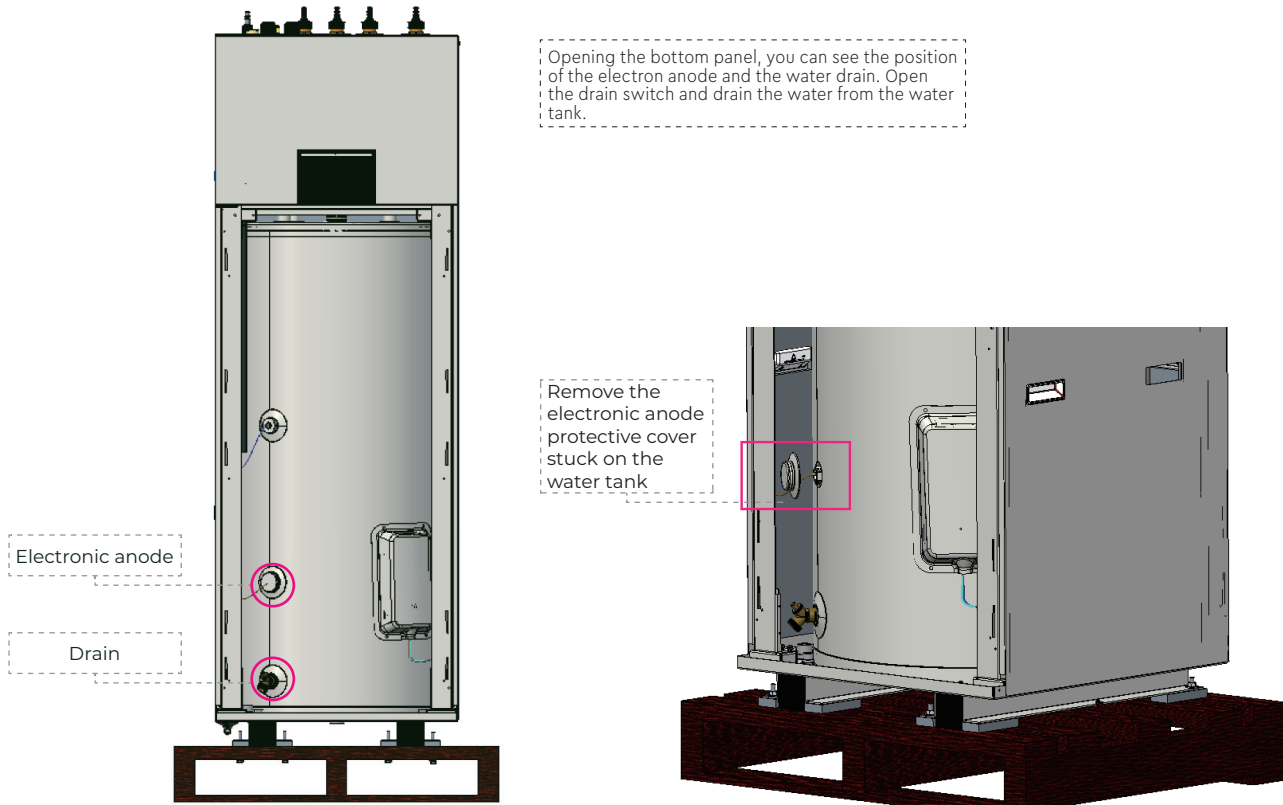

OVERALL DIMENSIONS OF INDOOR UNITS

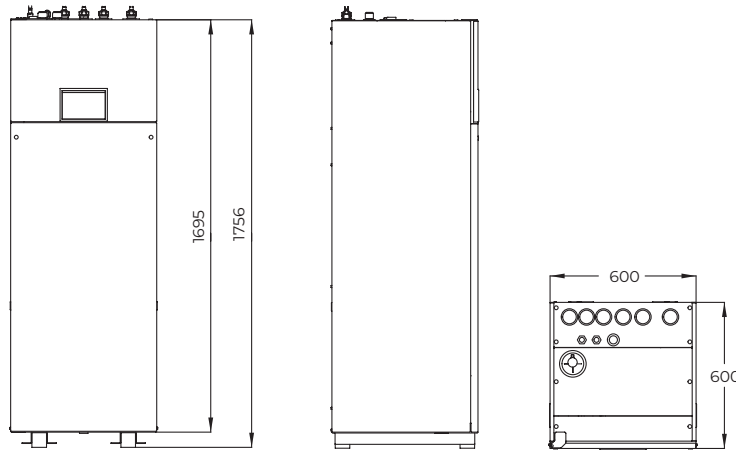

| No. | Description | | Connection thread |
|-----|------------------------------------|------|---|
| 1 | Diameter of outlet pipe (water) | | 1" Male BSP |
| 2 | Diameter of return water flow pipe | | 1" Male BSP |
| 3 | Tap water | | 1" Male BSP |
| 4 | DHW | | 1" Male BSP |
| 5 | Liquid pipe | 1/4" | CH-HP4.0WTSIRK4(I), CH-HP6.0WTSIRK4(I), CH-HP8.0WTSIRK4(I), CH-HP10WTSIRK4(I), CH-HP12WTSIRK4(I), CH-HP14WTSIRK4(I), CH-HP16WTSIRK4(I), CH-HP8.0WTSIRM4(I), CH-HP10WTSIRM4(I), CH-HP12WTSIRM4(I) CH-HP14WTSIRM4(I), CH-HP16WTSIRM4(I) |
| 6 | Gas pipe | 1/2" | CH-HP4.0WTSIRK4(I), CH-HP6.0WTSIRK4(I), CH-HP8.0WTSIRK4(I), CH-HP10WTSIRK4(I), CH-HP8.0WTSIRM4(I), CH-HP10WTSIRM4(I) |
| 7 | Gas pipe | 5/8" | CH-HP12WTSIRK4(I), CH-HP14WTSIRK4(I), CH-HP16WTSIRK4(I) CH-HP12WTSIRM4(I), CH-HP14WTSIRM4(I), CH-HP16WTSIRM4(I) |

TECHNICAL PARAMETERS OF ALL IN ONE SERIES 1 PHASE

| | | | CH- HP6.0WTSIRK3 | CH- HP8.0WTSIRK3 | CH- HP10WTSIRK3 | CH- HP12WTSIRK3 | CH- HP14WTSIRK3 | CH- HP16WTSIRK3 |
|--|--------------|-----------|----------------------|---------------------|--------------------|--------------------|--------------------|--------------------|
| Capacity* | Cooling | kW | 5,80 | 7,00 | 8,50 | 11,00 | 12,60 | 13,00 |
| | Heating | kW | 6,00 | 8,00 | 9,50 | 12,00 | 14,00 | 15,50 |
| Power input* | Cooling | kW | 1,32 | 1,75 | 2,24 | 2,50 | 3,41 | 3,60 |
| | Heating | kW | 1,20 | 1,70 | 2,07 | 2,40 | 2,98 | 3,44 |
| EER * | | | 4,40 | 4,00 | 3,80 | 4,40 | 3,70 | 3,60 |
| COP* | | | 5,00 | 4,70 | 4,60 | 5,00 | 4,70 | 4,50 |
| Capacity* | Cooling | kW | 4,09 | 5,30 | 6,50 | 10,59 | 11,07 | 11,51 |
| | Heating | kW | 5,90 | 8,00 | 9,50 | 12,40 | 14,48 | 16,09 |
| Power input* | Cooling | kW | 1,28 | 1,73 | 2,27 | 3,79 | 4,18 | 4,49 |
| | Heating | kW | 1,51 | 2,14 | 2,64 | 3,29 | 3,93 | 4,44 |
| EER ** | | | 3,20 | 3,00 | 2,90 | 2,79 | 2,65 | 2,57 |
| COP ** | | | 3,90 | 3,70 | 3,60 | 3,77 | 3,68 | 3,62 |
| Refrigerant charge volume | | kg | 1,00 | 1,60 | 1,60 | 1,84 | 1,84 | 1,84 |
| Power supply | | | ~220-240V/50 Hz/1 Ph | | | | | |
| Sound pressure level | Cooling | dB (A) | 52 | | 55 | | 68 | |
| | Heating | dB (A) | 52 | | 55 | | 68 | |
| Dimensions (W×D×H) | Indoor unit | mm | 600×600×1756 | | | | | |
| | Outdoor unit | mm | 975×396×702 | 982×427×787 | | | 940×460×820 | |
| Net weight | Indoor unit | kg | 210 | | | | | |
| | Outdoor unit | kg | 55 | 82 | | | 110 | |
| Water circulating pipe inlet/outlet, DHW | | | 1" Male BSP | | | | | |
| Diameter of pipe | Liquid | Inch (mm) | 1/4" (6,35) | | | | | |
| | Gas | Inch (mm) | 1/2" (12,7) | | | 5/8" (15,6) | | |

NOTE

«*» capacity and power input are specified under the following conditions:

Cooling Water temperature: +23°C/+18°C; Outdoor temperature: +35°C DB; +24°C WB

Heating Water temperature: +30°C/+35°C; Outdoor temperature: +7°C DB; +6°C WB

«**» capacity and power input are specified under the following conditions:

Cooling Water temperature: +12°C/+7°C; Outdoor temperature: +35°C DB; +24°C WB

Heating Water temperature: +40°C/+45°C; Outdoor temperature: +7°C DB; +6°C WB

TECHNICAL PARAMETERS UNITHERM 3 ALL-IN-ONE, 3 PHASE

| | | | CH-HP12WTSIRM3 | CH-HP14WTSIRM3 | CH-HPWT16SIRM3 |
|--|--------------|-----------|----------------------|----------------|----------------|
| Capacity* | Cooling | kW | 11,00 | 12,60 | 13,00 |
| | Heating | kW | 12,00 | 14,00 | 15,50 |
| Power input* | Cooling | kW | 2,50 | 3,41 | 3,60 |
| | Heating | kW | 2,40 | 2,98 | 3,44 |
| EER * | | | 4,40 | 3,70 | 3,60 |
| COP * | | | 5,00 | 4,70 | 4,51 |
| Capacity* | Cooling | kW | 10,65 | 11,24 | 11,52 |
| | Heating | kW | 12,29 | 14,44 | 16,13 |
| Power input** | Cooling | kW | 3,74 | 4,13 | 4,38 |
| | Heating | kW | 3,09 | 3,63 | 4,16 |
| EER ** | | | 2,85 | 2,72 | 2,63 |
| COP ** | | | 3,98 | 3,98 | 3,88 |
| Refrigerant charge volume | | kg | 1,84 | 1,84 | 1,84 |
| Power supply | | | ~380-415V/50 Hz/3 Ph | | |
| Sound pressure level | Cooling | dB (A) | 62 | | |
| | Heating | dB (A) | 58 | | |
| Dimensions (W×D×H) | Indoor unit | mm | 600×600×1756 | | |
| | Outdoor unit | mm | 940×460×820 | | |
| Net weight | Indoor unit | kg | 210 | | |
| | Outdoor unit | kg | 110 | | |
| Water circulating pipe inlet/outlet, DHW | | | 1" Male BSP | | |
| Diameter of pipe | Liquid | Inch (mm) | 1/4" (6,35) | | |
| | Gas | Inch (mm) | 5/8" (15,6) | | |

NOTE:

«*» capacity and power input are specified under the following conditions:

Cooling Water temperature: +23°C/+18°C; Outdoor temperature: +35°C DB; +24°C WB

Heating Water temperature: +30°C/+35°C; Outdoor temperature: +7°C DB; +6°C WB

«**» capacity and power input are specified under the following conditions:

Cooling Water temperature: +12°C/+7°C; Outdoor temperature: +35°C DB; +24°C WB

Heating Water temperature: +40°C/+45°C; Outdoor temperature: +7°C DB; +6°C WB

ELECTRICAL PARAMETERS UNITHERM 3 ALL-IN-ONE

| | Power supply V/ Hz | Automatic switch (A) | The minimum cross-sectional area of the grounding wire (mm ²) | The minimum cross-sectional area of the power cable (mm ²) |
|--------------------|-----------------------|-------------------------|--|---|
| CH-HP6.0WTSIRK3(O) | ~220-240V/50 Hz/1 Ph | 16 | 1,5 | 1,5 |
| CH-HP6.0WTSIRK3(I) | | 20 | 6 | 6 |
| CH-HP8.0WTSIRK3(O) | | 25 | 4 | 4 |
| CH-HP8.0WTSIRK3(I) | | 40 | 6 | 6 |
| CH-HP10WTSIRK3(O) | | 25 | 4 | 4 |
| CH-HP10WTSIRK3(I) | | 40 | 6 | 6 |
| CH-HP12WTSIRK3(O) | | 32 | 6 | 6 |
| CH-HP12WTSIRK3(I) | | 40 | 6 | 6 |
| CH-HP14WTSIRK3(O) | | 40 | 6 | 6 |
| CH-HP14WTSIRK3(I) | | 40 | 6 | 6 |
| CH-HP16WTSIRK3(O) | | 40 | 6 | 6 |
| CH-HP16WTSIRK3(I) | | 40 | 6 | 6 |
| CH-HP12WTSIRM3(O) | ~380-415V/50 Hz/3 Ph | 16 | 2,5 | 2,5 |
| CH-HP12WTSIRM3(I) | | 20 | 4 | 4 |
| CH-HP14WTSIRM3(O) | | 16 | 2,5 | 2,5 |
| CH-HP14WTSIRM3(I) | | 20 | 4 | 4 |
| CH-HP16WTSIRM3(O) | | 16 | 2,5 | 2,5 |
| CH-HP16WTSIRM3(I) | | | 4 | 4 |

NOTES:

- A. If circuit breakers with leakage protection are used, the trip time should be less than 0.1 second and the leakage current should be 30 mA.
- B. The diameter of the power cables selected above is determined based on the assumption that the distance from the distribution box to the device is less than 75 m. If the cables are laid at a distance of 75 to 150 m, then the diameter of the power cable must be increased.
- C. The power source must meet the rated voltage of the device and must be connected to a separate electrical line.
- D. All electrical work must be performed by professional technicians in accordance with local codes and ordinances.
- E. Implement safety grounding. The grounding wire must be connected to a special grounding line in the building, the connection must be made by professional technicians.
- F. The switch and power cord specifications in the table above are based on the maximum power (maximum current) of the device.
- G. The power cable specifications in the table above refer to a stranded copper cable in a protective sheath (e.g. YJV cross-linked polyethylene insulated power cable) used at +40 °C and resistant to +90 °C (see IEC 60364-5-52). If the requirements are changed, the cables must be replaced according to the relevant standard.
- H. The switch specifications in the table above refer to the switch with an operating temperature of +40 °C. In the event of a change in conditions, they must be changed in accordance with the current national standard.
- I. An automatic switch must be installed in the power supply line. Automatic switch with disconnection of all poles. The opening distance between the contacts should be at least 3 mm.

PIPE CONNECTION OF UNITHERM 3 ALL-IN-ONE

| | Diameter of pipe | | Length B | | Height A | | Additional |
|-----------------|------------------|--------|----------|--------|----------|------|-------------|
| | Gas | Liquid | Standard | Max | Standard | Max | Refrigerant |
| ALL-IN-ONE | | | | | | | |
| CH-HP6.0WTSIRK3 | 1/2" | 1/4" | 5 m | 20 m | 0 m | 15 m | 16 g/m |
| CH-HP8.0WTSIRK3 | 1/2" | 1/4" | 5 m | 25 m | 0 m | 15 m | 0 g/m |
| CH-HP10WTSIRK3 | 1/2" | 1/4" | 5 m | 25 m | 0 m | 15 m | 0 g/m |
| CH-HP12WTSIRM3 | 5/8" | 1/4" | 5 m | 15 m * | 0 m | 15 m | 0 g/m |
| CH-HP14WTSIRM3 | 5/8" | 1/4" | 5 m | 15 m * | 0 m | 15 m | 0 g/m |
| CH-HP16WTSIRM3 | 5/8" | 1/4" | 5 m | 15 m* | 0 m | 15 m | 0 g/m |
| CH-HP12WTSIRK3 | 5/8" | 1/4" | 5 m | 15 m* | 0 m | 15 m | 0 g/m |
| CH-HP14WTSIRK3 | 5/8" | 1/4" | 5 m | 15 m* | 0 m | 15 m | 0 g/m |
| CH-HP16WTSIRK3 | 5/8" | 1/4" | 5 m | 15 m* | 0 m | 15 m | 0 g/m |

* Under certain conditions, the length can be increased to 25 m.

NOTES:

- A. Additional refrigerant charging is not required if the pipe length is less than 10m, if the pipe length is more than 10m, additional refrigerant charging is required according to the table. For example: if a 10 kW model is installed at a distance of 25 m, you should add $(25-10) \times 16 = 240$ g of refrigerant.
- B. Rated capacity is based on standard pipe length and maximum allowable length is based on working length. The grease intake loop should be installed every 5-7 meters if the external unit is located above the internal unit (hydro module).
- C. Each 90° bend is approximately equal to 0.5 meters of pipe length.

OVERALL DIMENSIONS OF OUTDOOR UNIT

